

## ITEM OPPORTUNITY SYNOPSIS:

Item to be Scouted

Supplier Scouting Number

NAICS Code, if known

<b>TECHNICAL INFORMATION:</b>	<b>1. Describe the Item:</b>	<b>a. Please describe the item application/ the end use of item.</b>
	<b>2. Summary of Technical Specifications and Performance Requirements:</b>	<b>b. Provide the item number if applicable: (N95 Mask vs Protective Mask).</b>
	<b>2. Summary of Technical Specifications and Performance Requirements:</b>	<b>a. Provide dimensions / size / tolerances / performance specifications for the item.</b>
		<b>b. List required materials needed to make the product, including materials of product components, if applicable.</b>
		<b>c. Are there applicable certification requirements to supply this item? (i.e. ISO certification) Are there any applicable regulations that apply to the production of this item? (i.e. FDA regulations or EPA regulations) Are there any other standard requirements? (i.e. ASME Standard, IEEE Standard) Please specify.</b>
<b>2. Summary of Technical Specifications and Performance Requirements:</b>	<b>d. Describe the manufacturing processes (elaborate to provide as much detail as possible).</b>	
	<b>e. Additional Comments: Is there other information that would impact the item's performance or usefulness? Please explain.</b>	

<b>BUSINESS INFORMATION:</b>		<b>f. Potential Business Volume Estimate (i.e., # Units Per Day, Month, Year):</b>
		<b>g. Target Price / Unit Cost Information:</b>
	<b>3. Delivery Requirements:</b>	<b>a. When is it needed by? (Immediate, 30 Days, 6 months, etc.)</b>
		<b>b. Describe packaging requirements (i.e., individually/ group packaging).</b>
	<b>c. Where is this opportunity located? Is there a preferred shipping proximity - if applicable?</b>	
<b>4. Additional Comments:</b>	<b>a. Opportunities will be posted for 30 days unless another timeframe is given below</b>	
	_____ days	
	<b>b. Is there other information you would like to include?</b>	

Photos or diagrams of the item (helpful but not required).



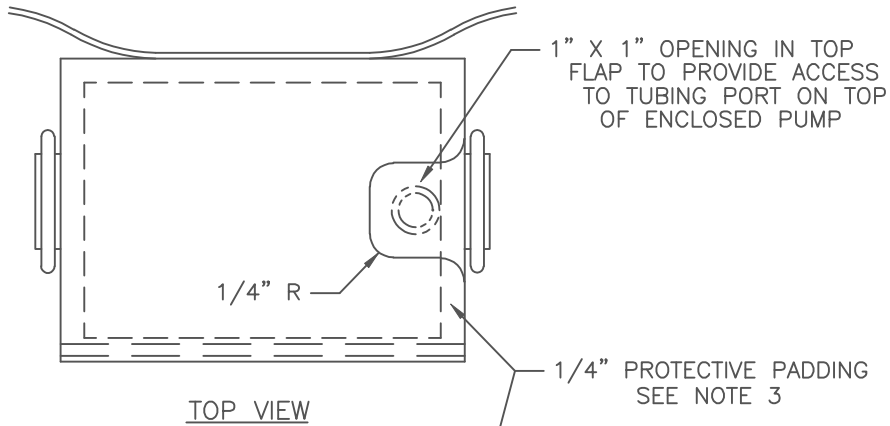

**NOTE:**

- 1.) A SAMPLE PUMP (SKC AIRCHEK TOUCH) WILL BE PROVIDED BY SKC.
- 2.) COLOR: BLACK
- 3.) 1/4" PROTECTIVE PADDING IN 4 SIDES & BOTTOM
- 4.) ADJUSTABLE SHOULDER (1-1/2") & WAIST BAND (2") TO BE INCLUDED
- 5.) XXXXX REFERENCES SEWING BUT EXACT LOCATION AND TYPE OF STITCH AS WELL AS STITCH REINFORCEMENTS ARE TO MEET TEXTILE INDUSTRY STANDARDS AS NEEDED TO SUPPORT THE WEIGHT OF THE PROVIDED SAMPLE.
- 6.) COLOR OF SKC LOGO IS WHITE. POSITION AS SHOWN. ARTWORK TO BE PROVIDED BY SKC
- 7.) POUCH DIMS ARE FOR REFERENCE. POUCH IS TO BE SIZED TO MATCH PROVIDED SAMPLE PRODUCT.

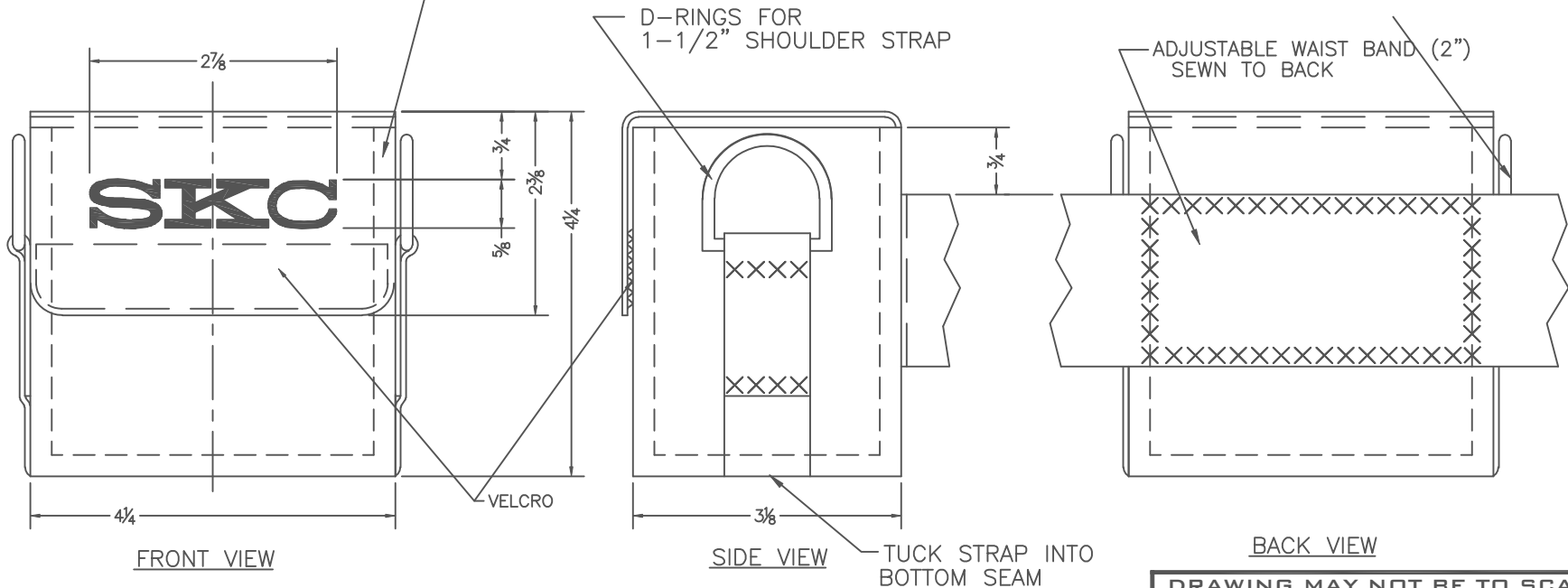

REVISIONS					
REV NO	BY	DATE	DESCRIPTION	DATE	APPV'D

AUTHORIZATION		
DRAWN	RSP	08OCT15
CHECKED	TBR	08OCT15
APPV'D	MAM	02NOV15
DIMENSIONS ARE IN INCHES [MILIMETERS] TOLERANCES ARE STANDARD COMERCIAL		
FRACTIONS ±	ANGLES ±	DEC ±

**DRAWING MAY NOT BE TO SCALE**



863 VALLEY VIEW RD.  
EIGHTY FOUR, PA 15330  
U.S.A.

TITLE  
PROTECTIVE POUCH  
AIRCHEK TOUCH SAMPLE PUMP

IDENTIFICATION NO.  
50541

PLOT SCALE 1:2    SHT 1 OF 1

THIS INFORMATION IS CONFIDENTIAL AND PROPRIETARY TO SKC INC. AND MAY NOT BE REPRODUCED IN ANY FORM OR TRANSMITTED IN WHOLE OR PART WITHOUT PRIOR WRITTEN AUTHORIZATION OF SKC INC.

**RELEASED — EFFECTIVE**